

Commercialization of 1 Watt Consumer Electronics Power pack

P. I. Chuck Carlstrom

MTI Micro Fuel Cells Inc.

May 12, 2011

Project

ID:H2RA001

This presentation does not contain any proprietary, confidential, or otherwise restricted information

Overview

Timeline

- Start date: July 15, 2009
- End date: March 30, 2011
- 100% complete

Budget

- Project funding:
 - DOE share: \$2.99M
 - Contractor share: \$3.01M+
 - Additional NYSERDA: \$.298M

Barriers

- Manufacturability
- Cost
- Performance & degradation
- Market acceptance

Partners

- Methanol Foundation
- Component suppliers
- Project lead: MTI Micro Fuel Cells

Relevance: Project Objectives

Demonstrate and field test a commercially viable one Watt Direct Methanol Fuel Cell (DMFC) charger for consumer electronic devices

- Reduce cost to attain a competitively priced product
- Design for manufacture & ease of assembly
- Demonstrate performance across range of environmental conditions
- User field test of 75 fuel cell powered chargers



Key Benefits of DMFC Charger

- ✓ Grid-free electrical power
- ✓ No AC adapter required
- ✓ Charge on-the-go
- ✓ Generates electricity anywhere at any time
- ✓ Small cartridge = energy of 17 AA batteries
= size of 4 AA batteries



Mobion[®] cartridge energy capacity (25Whrs)

17x AA Batteries

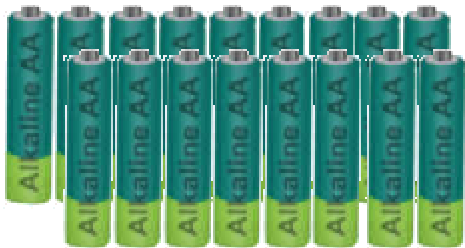

1 Mobion[®] cartridge
*25 watt hours of
electricity*
Equivalent Energy

Up to **12x** (2 Wh) Charge
for Messaging Phone



Up to **7x** (3.8 Wh) Charge
for Smartphone Phone



Relevance to ARRA

- Alignment with ARRA goals of saving and creating jobs:
 - Directly created/ retained 11 FTE jobs in NY state
 - The leverage DOE funds offered enabled MTI to obtain private investment
 - DOE funds used by MTI for labor – no direct materials or capital

- Alignment with FCT ARRA project goals of accelerating the commercialization and deployment of fuel cells:
 - Components have been redesigned for low cost, high volume manufacturing
 - 75 fuel cell systems were deployed in field test

Plan & Approach

Development followed by field deployment

Submitted environmental and safety plans in fall of 2009

Phase I: Redesign for low cost manufacturing

- Redesigned all components to be produced using processes capable of low cost and high volume.
 - Plastic components went from machined to injection molded
 - Sheet metal components went from being machined to formings and stampings
 - Laser cut free-standing gaskets were replaced with profiled gaskets over-molded onto components they seal
- Test stacks/engines for improved performance & degradation
- Test complete systems to predetermined performance metrics

Go/No-Go PHASE GATE: Must achieve predetermined performance, cost, and manufacturing goals.

Phase II: Complete tooling for all components

- Build and test Beta systems with components from hard tooling

Phase III: Deploy 75 units in the field for real world feedback

- Build and test all units to quantify performance prior to shipping.
- Create Web support for online sign-up, user support, and feedback.
- Execute field test and analyze feedback for potential product improvements

Go/No-Go criteria

Target metrics vs. results achieved

- To pass phase gate system had to achieve predetermined levels of
 - ✓ Continuous run power (Achieved 1.04W net, Target was 1W net)
 - ✓ Energy from 1st cartridge (Achieved 28.9Whr, Target was 26Whr)
 - ✓ Life time (Target of 2000 hrs)
 - Achieved over 6000hrs at 5% loss per 1000 hrs on Stack/Engine
 - Achieved over 2000 hrs on multiple systems
 - ✓ High volume unit production cost projection (\$ MSRP target achieved but confidential)
 - ✓ Total labor content reduction (Achieved 74% reduction, Target was 50%)
- Demonstrate robust operation for consumer electronics application:
 - ✓ 0-40C temperature operation with 10%-90% relative humidity
 - ✓ 0-8K Feet altitude operation
 - ✓ Other: Orientation Independence, drop testing, touch temperatures

Achieved metrics and passed Phase gate on-schedule (November 2009)

System Approach

Mobion: Unique DMFC architecture

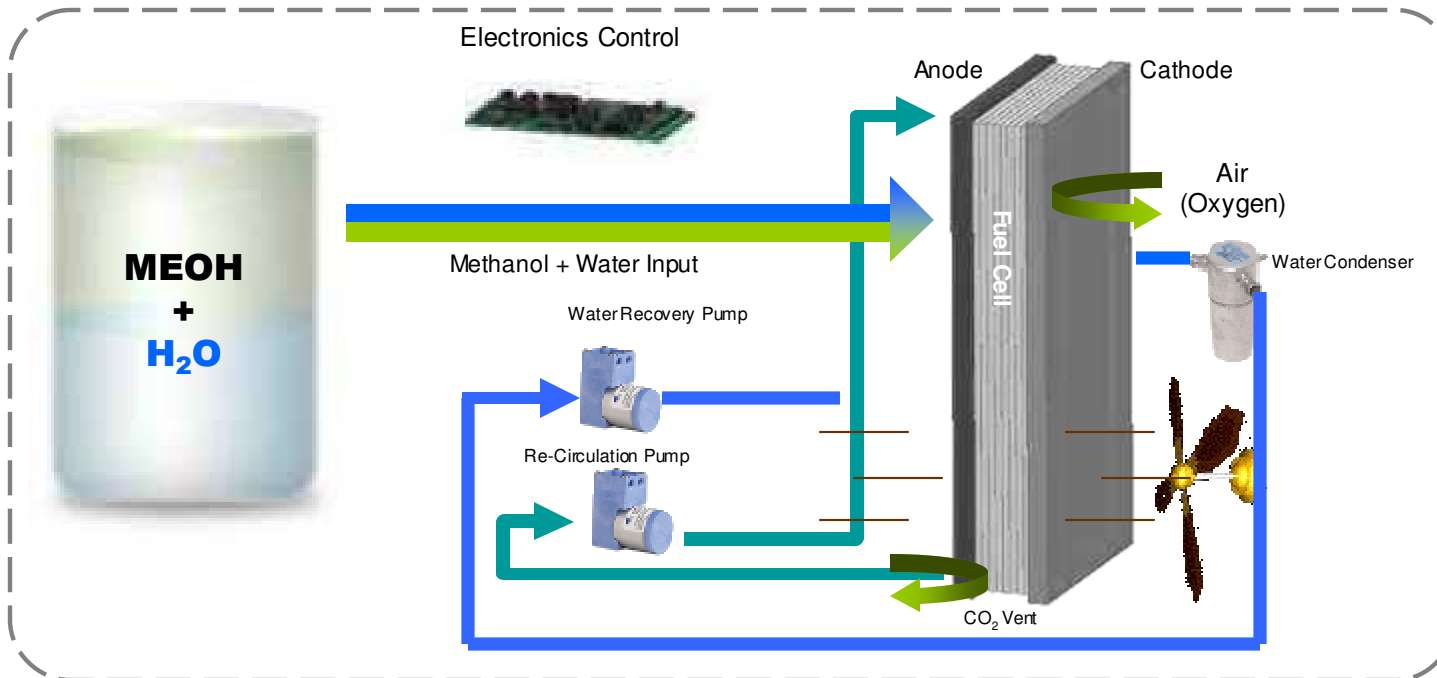

Active DMFC

Large and complicated system with more components.

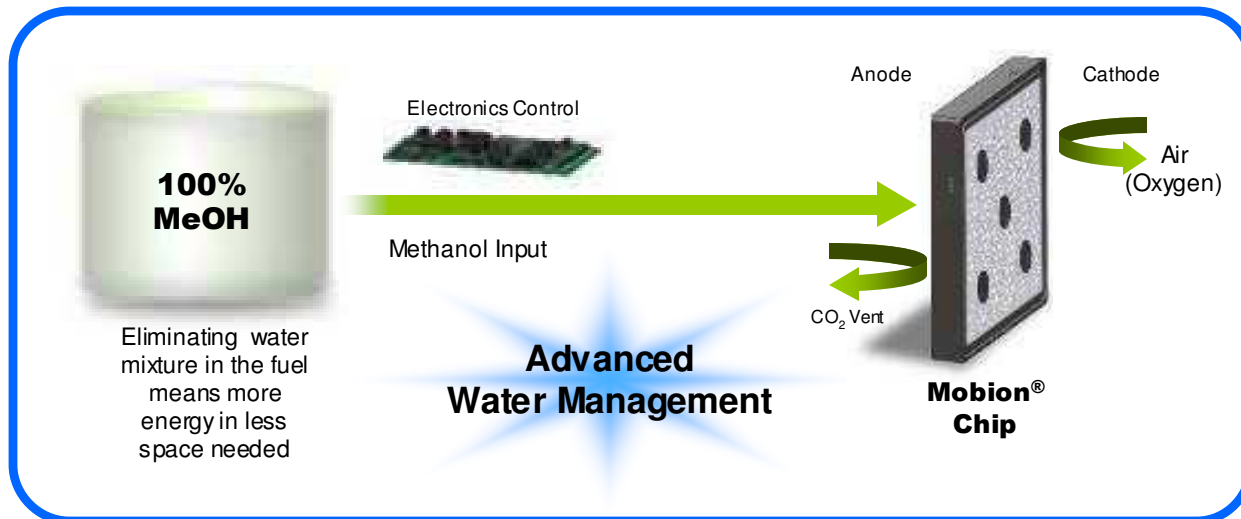

Advantages

- ✓ No freeze issue
- ✓ More robust
- ✓ Higher energy density
- ✓ Compact
- ✓ Easy to customize

Technical Accomplishments:

Over 90% fuel utilization of stack/engine

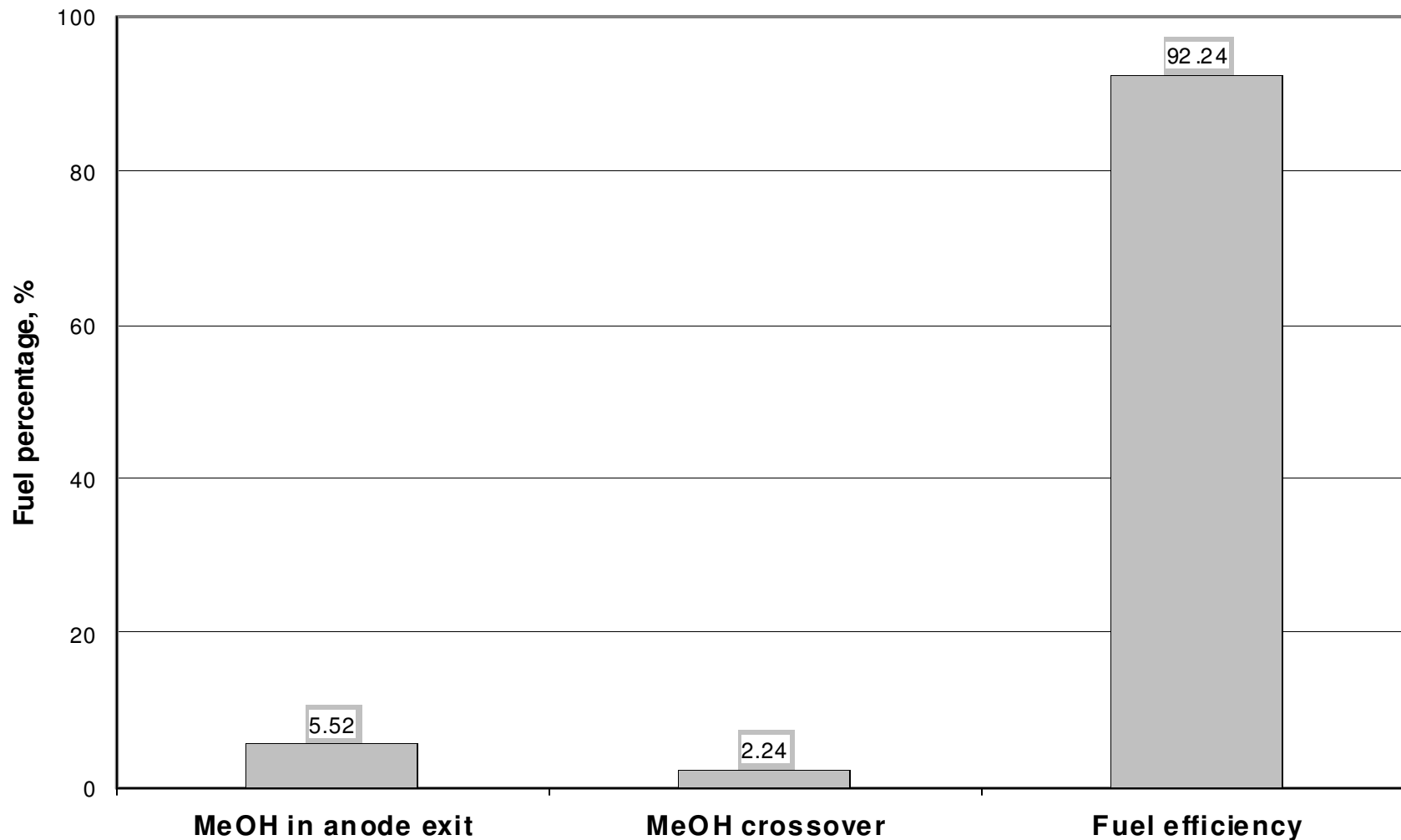

Negligible crossover results in high efficiency and long life

Demonstrated Low Decay

Normalized stack/engine power

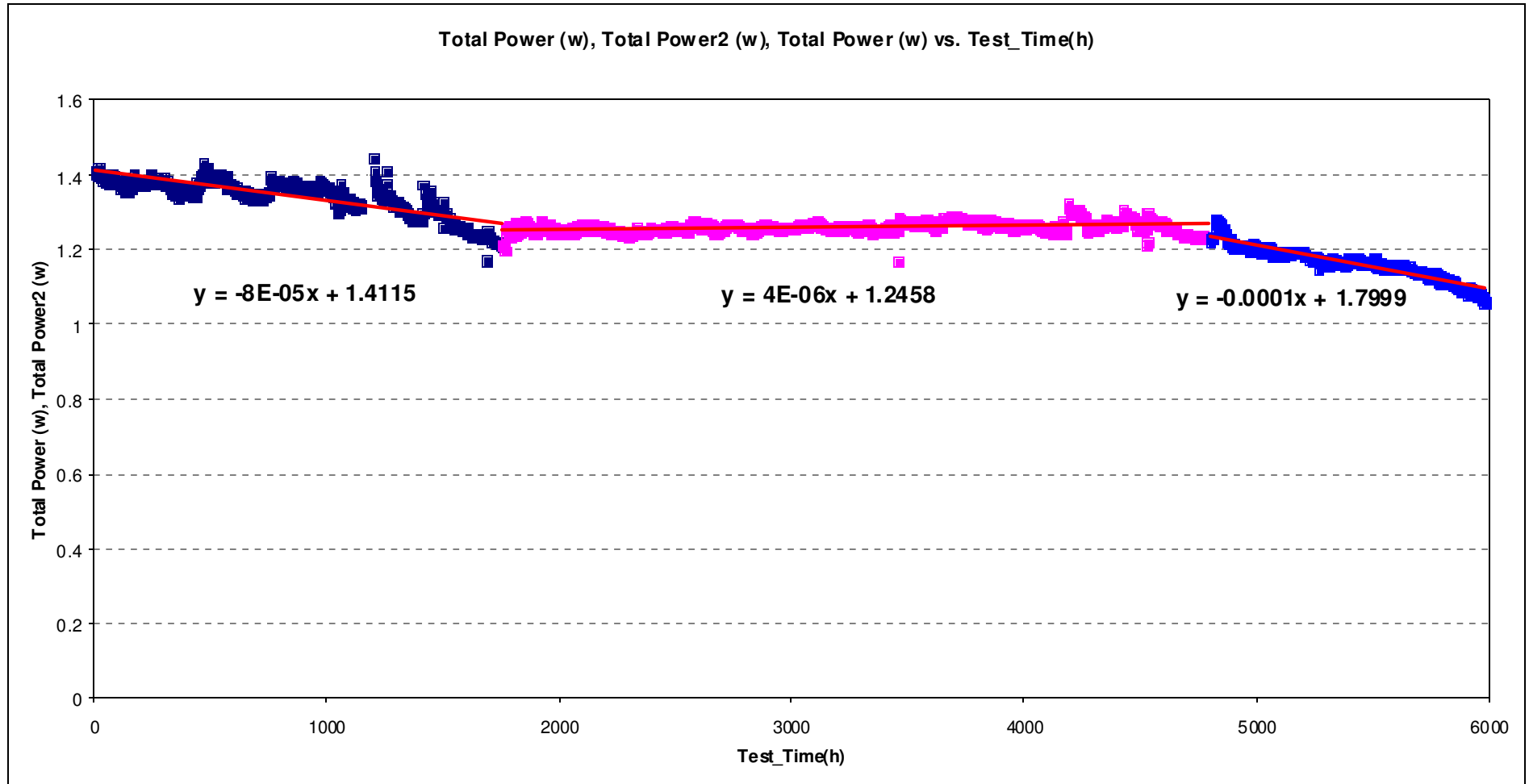

*Over 6000 hours of run time
Decay rate less than 5% per 1000 hours*

Ambient Temperature Latitude

System Net Power Density vs. Temperature at 50 RH

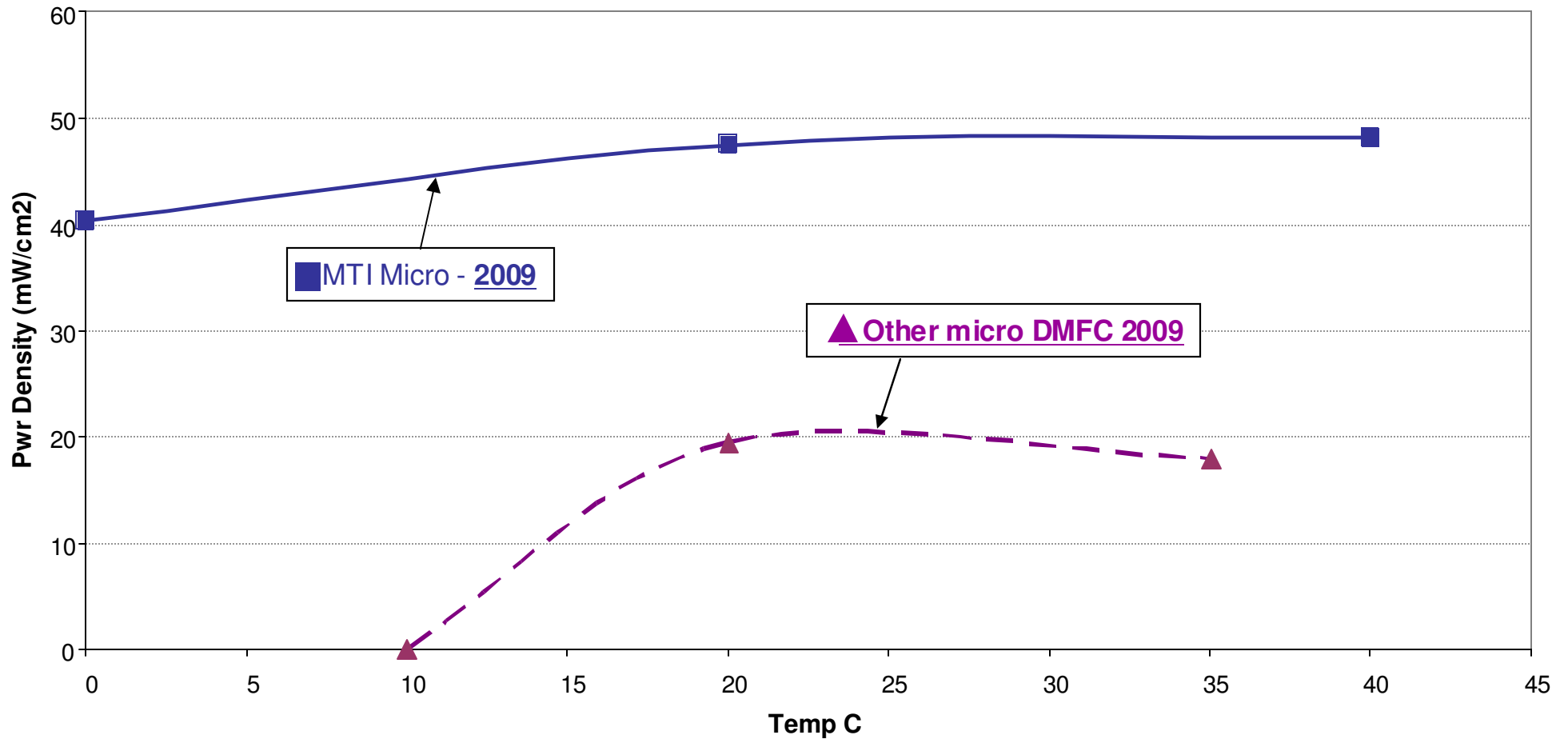

MTI system provides stable power and more than twice the power density within the Consumer Electronics temperature range of 0 to 40°C

Accomplishments: 75 Unit Field Test

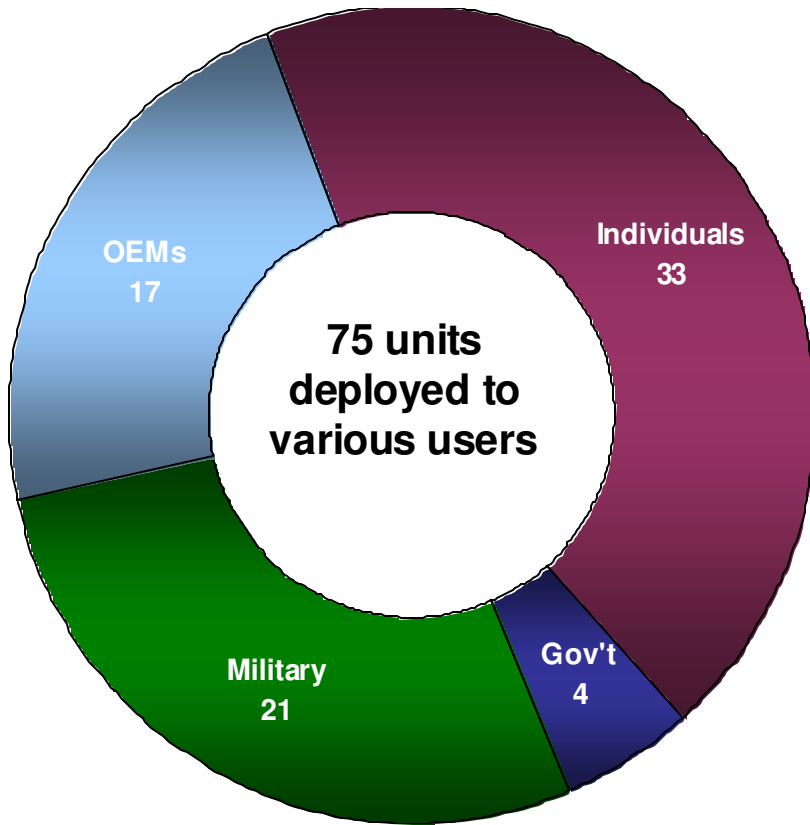

First 5 shipments
Via FEDEX Domestic Shipment
Sealed paint can
Regular shipment: 3 to 5 days
Average Cost: \$150.00 each

Negotiated shipment
Via USPS Domestic Shipment
Regular white cardboard box
Surface only shipment: 3 to 5 days
Average Cost: \$7.95 each

What's in the box?



1 Mobion® handheld generator



2 Mobion® cartridges



1 USB Cable + Tips (Mini, Micro and Apple)



2 Quick start Guides

Field Test Feedback

“We were impressed with the form factor and with the chemical conversion technology. It repeatedly charged our iPhones in a timeframe similar to that from a standard electrical outlet.” - OEM

“Just finished off my first cartridge today. I charged my (iPhone) phone approx 10x from ~25% to 100% battery before it needed replacement” - OEM

“The device works excellently and has not provided many inconsistencies. Mostly, not being able to have the fuel cell in an enclosed space (i.e., laptop bag) while it is generating power was an inconvenience though not a major problem.” – Individual user

“Alternative energy on the battlefield is evolving into one of the most salient issues of the day. We believe that despite initial concerns, Mobion should continue advancement of this unique technology to potentially meet some of the existing and future tactical energy requirements.” - Military

Results from Field Test:

User feedback – What users liked

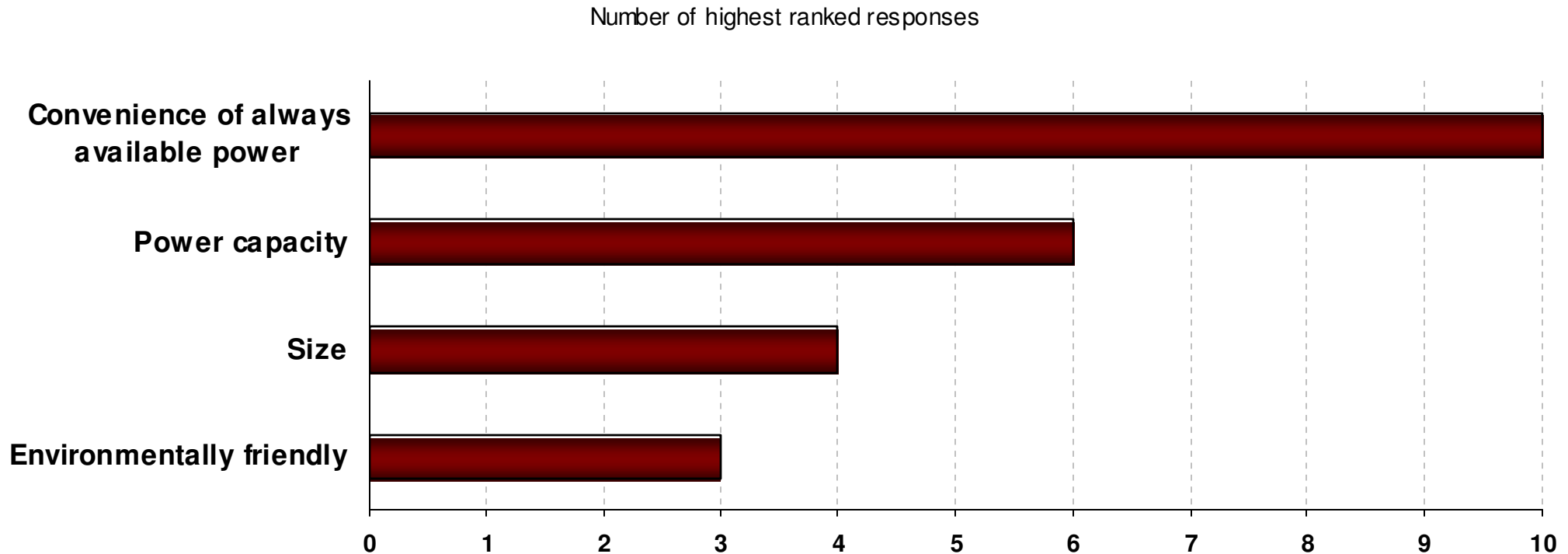

Always having power available is valued as most important to the user

Results from Field Test:

User feedback - Areas for improvement

Number of highest ranked responses

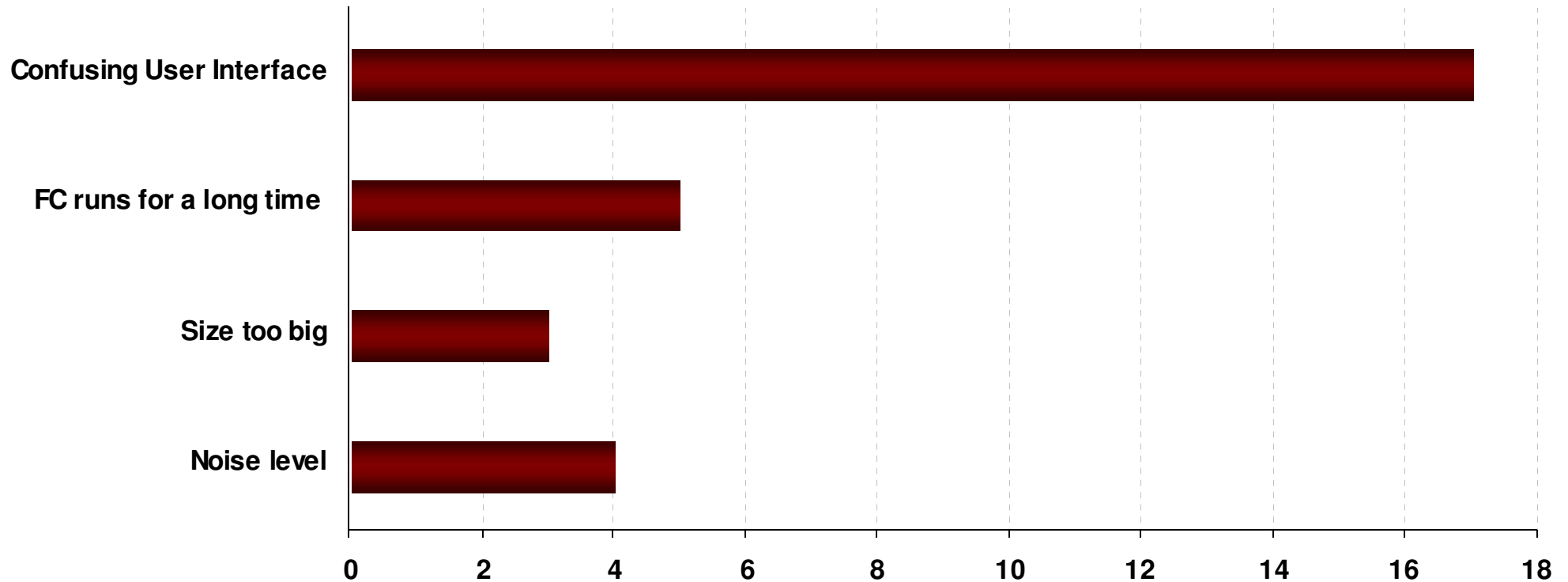

User interface identified as an area in need of improvement

Field Test Identified Improvements

Improvements complete or in-process based on user feedback:

- Identified and fixed phone compatibility issues early in the field test.
- Several software algorithm improvements implemented and being developed.
- Improved sound isolation
- A new user interface with a single on-off switch is being developed

User interface used for field trial

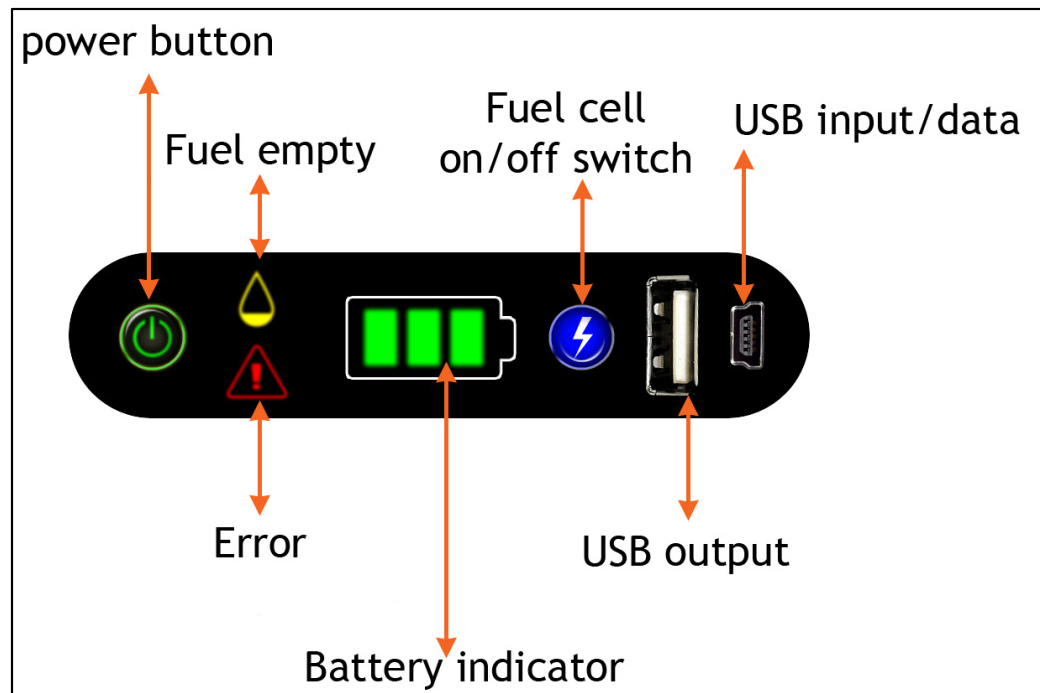

- **Two switch user interface was confusing to users**

- **New user interface being developed is simpler and more intuitive**

Collaboration

- Methanol Foundation (Phase I & Phase II):
 - Consumer and environmental safety & associated regulatory standards development and compliance
 - Worked with key states EPA on cartridge & system end-of- life disposal and recycling
- Fuel cell component suppliers:
 - MEA, membranes, plate and seal materials
 - Share performance and life test results with partners
 - Qualified multiple sources of supply for key components
- Future customers and OEMs
 - OEM and end user field test participants
 - Military, Government & National labs (NREL, ANL, DOE, DOD) field test participants

Summary

- **Relevance:**
 - Project is in direct alignment with ARRA and FCT ARRA goals
 - 11 FTE jobs retained in NY state
 - Improved manufacturability to accelerating commercialization
 - Deployed 75 fuel cell systems into field for critical user feedback
- **Approach:**
 - All technical performance targets/metrics have been achieved
 - Passed Go/No-Go phase gate in November 2009
- **Technical Accomplishments:**
 - Reduced cost and improved manufacturing
 - Machined components to plastic injection molding or metal stamping
 - Over 50% reduction in labor content to build a system
 - Demonstrated high performance, fuel efficiency, and low degradation
 - Demonstrated system temperature & humidity latitude (0C-40C, 0-90%RH)
 - Completed 75 units field trial and attained valuable end user feedback
- **Collaborations**
 - Methanol Foundation:
 - Cartridge and system regulatory standards development & compliance
 - End of life disposal and recycling
 - Component suppliers and commercialization partners
- **Future work**
 - Prepare comprehensive final report

Thank You!



A power generator that fits in your hand!